



HU35025

UNIVERSAL DIGITAL PRESSURE TESTER - MASTER KIT



THIS KIT MEASURES:



PATENT PENDING

SAVE, EXPORT, PRINT AND SHARE YOUR RESULTS!



ONE SINGLE KIT REPLACES DOZENS OF STANDARD DIAGNOSIS KITS

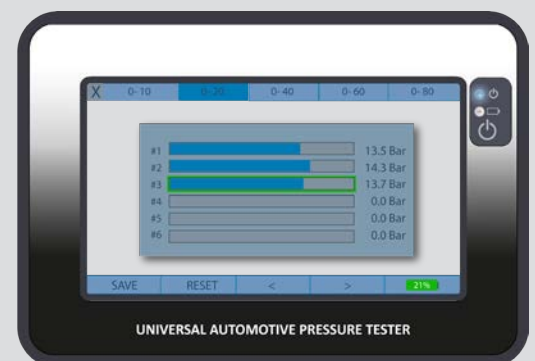

Kit includes:

- Tester (see spec page 3)
- Sensor 0 to 300Bars
- Sensor 1 > 3Bars
- Universal Diesel Compression Adaptor
- Universal Petrol Compression Adaptor
- Eight specific professional quick coupling adaptors
- Vacuum adaptors

OPTIONAL



WITH THIS SINGLE INNOVATIVE ADAPTOR, SAVES AT LEAST 50 GLOW PLUG ADAPTORS OR MORE!

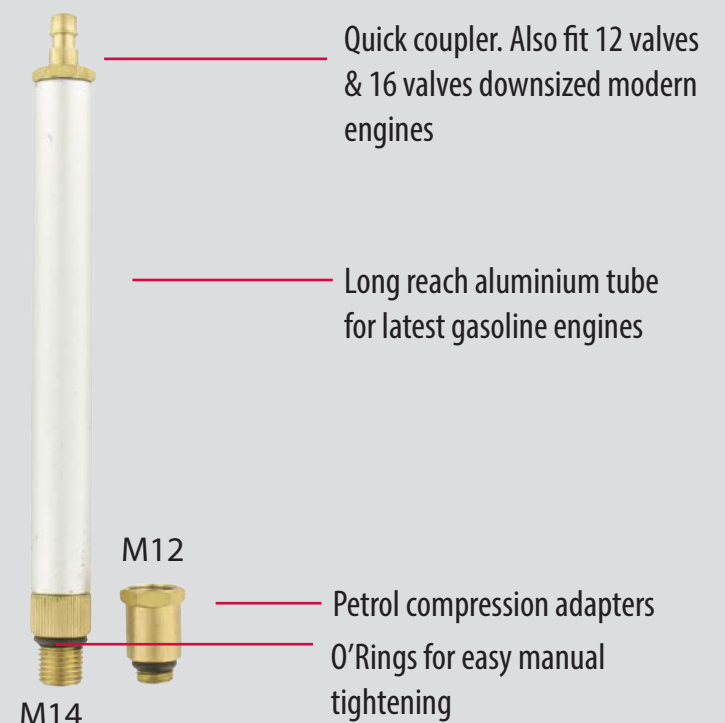
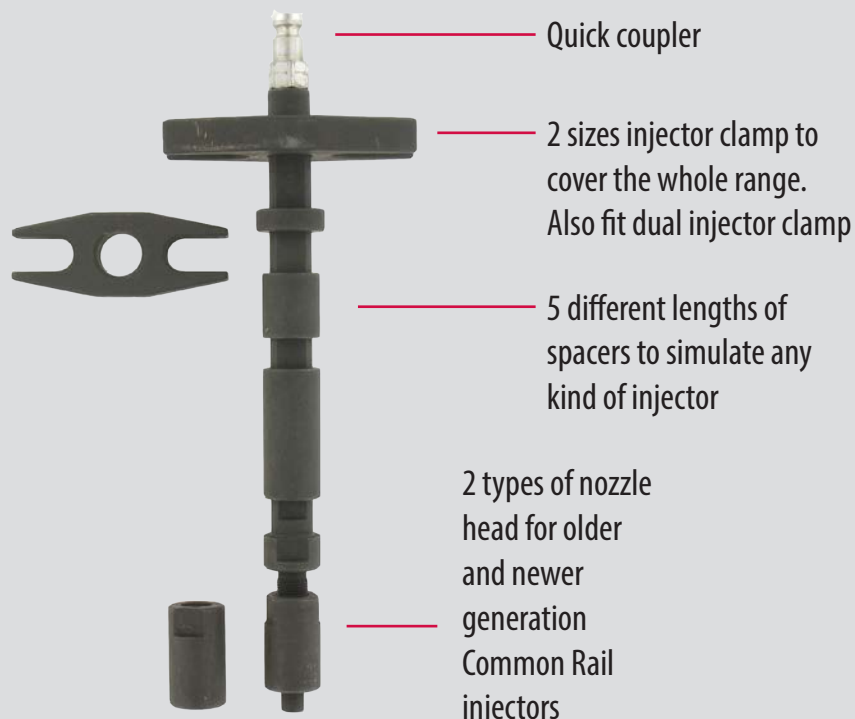

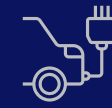

HU35026



DIESEL HIGH PRESSURE KIT

- Easily & safely test the diesel common rail pressure
- Thanks to this set, the mechanic will be able to safely test the diesel common rail pressure, both in line ("in serie with engine running") and for direct pump pressure (Cranking the engine)
- Unlike simply having the pressure information with the sensor of the car (this sensor may have an issue), our set provides all the hardware (special sensor, plugs, hoses) to perform a very precise and accurate test in association with our digital tester HU35025 (or HU35020). The hoses included in the set will allow to measure and diagnose most usual common rail engine.
- Kit includes a 2000bar sensor, a sensor plug for direct pump pressure, 2x M12 x 150 hoses for most common applications and a retrieving reservoir

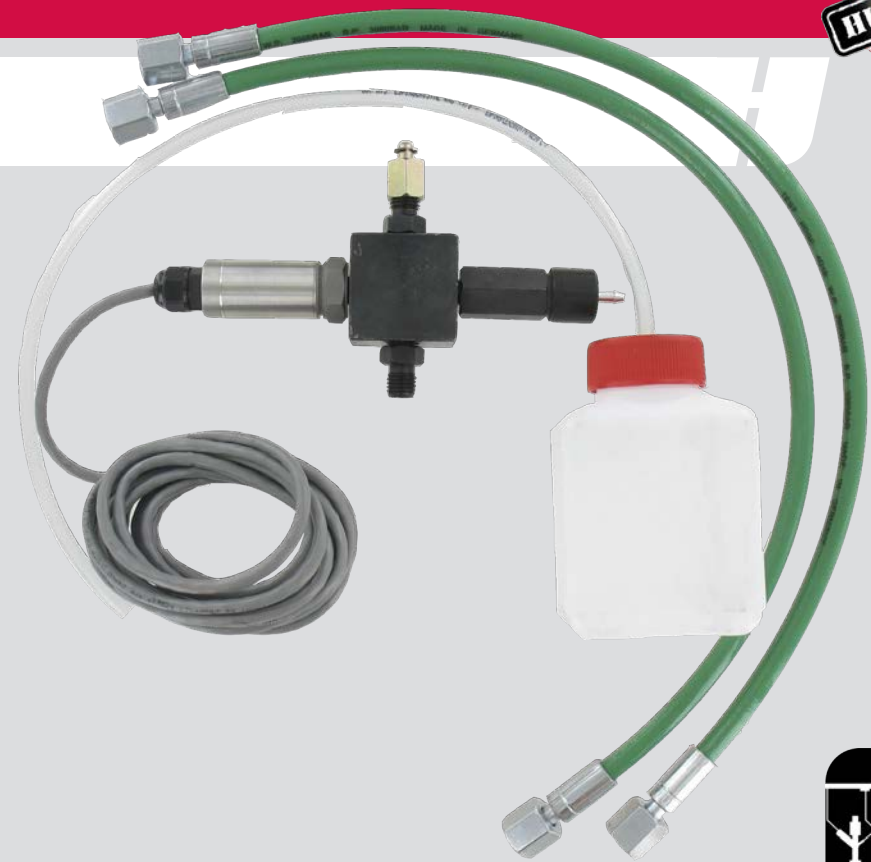

HU35030



COMMON RAIL CAPS SET

- Used in association with HU35026, this set will allow to close injectors fuel inlet directly on the common rail. The purpose of this operation is to identify if an injector is leaking or not.
- Works for 3, 4, 5 and 6 cylinders engines.
- Kit includes 6x M12x150 plugs and 6x M14x150 plugs



HU35031



COMMON RAIL DUMMY REGULATOR SET

- This set, used in association with HU35026, will allow to bypass the pump's regulator and measure the pressure to diagnose any regulator or pump issue.
- After observing the weak pump pressure : Simply remove the regulator, and choose the right dummy plug to bypass and seal the port. If the pressure comes back to normal, the regulator causes the loss of pressure. If the pressure stays too low, the pump is defective. This test is recommended by manufacturer of high pressure pumps.
- Kit includes 8 different dummy to seal any regulator ports



DISMOUNT REGULATOR



CHOOSE DUMMY

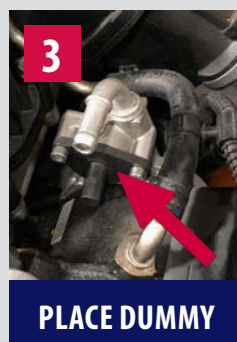

PLACE DUMMY





HU35020



UNIVERSAL DIGITAL PRESSURE TESTER - COMPRESSION PETROL & DIESEL

PATENT PENDING



SAVE, EXPORT, PRINT AND SHARE YOUR RESULTS!



1. Tester

- 7" Color TFT display with resistive touch panel
- Battery: LiPo 3,7V / 2000mA
- USB smart battery charge with led indicator
- PC connection by USB port
- ABS enclosure with rubber bumper (Hubitools design)
- All screws are mounted on brass inserts
- 1/4 thread brass insert at back to fix suction cup, etc...

- Possible recalibration 
- User-friendly touchscreen

2. Sensors

- Sensor -1 to 3 Bar
- Sensor 0 to 300 Bar

Kit includes:

- Tester
- Sensor 0 to 300Bars
- Universal Diesel Compression Adaptor
- Universal Petrol Compression Adaptor

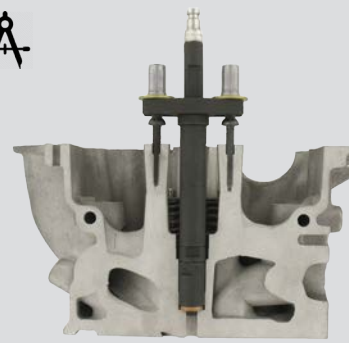

ONE KIT TO MEASURE BOTH GASOLINE AND DIESEL COMPRESSIONS



Compression
PETROL



Compression
DIESEL



MI8550

MITYVAC METAL HAND PUMP KIT

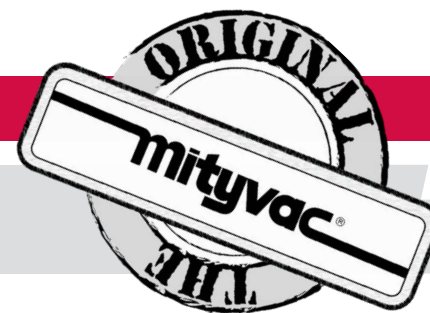

GIVE YOUR PUMP A DIGITAL ACCURACY OF 0.01BAR!

USE THE MITYVAC PUMP IN COMBINATION WITH THE HU35025 UNIVERSAL PRESSURE TESTER!



HU41010

DIESEL INJECTOR SEAL EXTRACTOR



- Removal of diesel injector seal that is completely clogged and stuck in the housing
- Slide hammer of 1000 grams to remove the most difficult seals
- Integrated hexagonal socket in the slide hammer to screw the extractor into the seal (left-handed thread)
- Conical remover with double thread entry
- Provided with two removers: One for light vehicles (LV) and the other for light utility vehicles (LUV)
- No risk of parts dropping into the cylinder
- No adjustment
- Very easy to use
- Very quick
- High quality equipment for professional use

**EASY REMOVAL OF
JAMMED SEALS**

**2 REMOVERS:
FOR LV AND LUV**

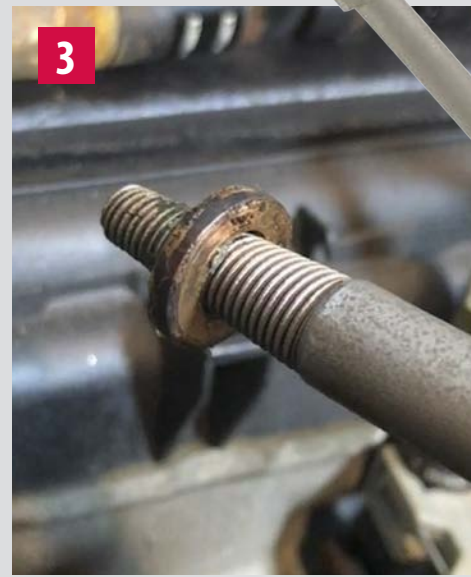
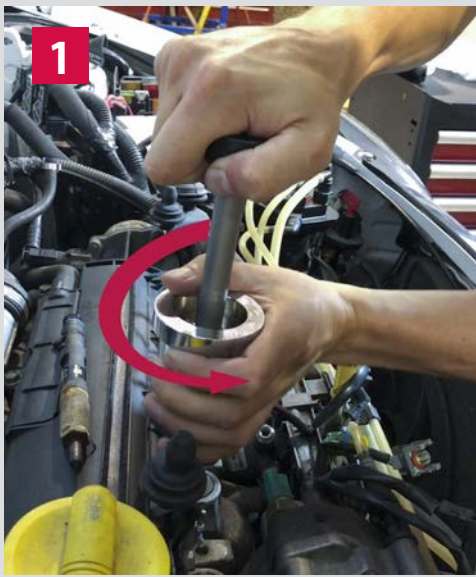

HU41039

UNIVERSAL INJECTOR SEAT CLEANING SET

ALL YOU NEED BEFORE CHANGING INJECTOR



- Kit includes :
 - 2 metal brushes Ø 20mm and 25mm for injector hole cleaning
 - 2 front brushes for injector seat cleaning
 - 1 front brush extension
 - 2 seal plugs to close the injector hole while cleaning
 - 1 seal plug holder to place and remove the plug
 - a sanding kit (paper and paper support)
- This set will allow the technician to make a perfect job before placing the new injector!
- Cleaning the injectors holes after the extraction is extremely important.

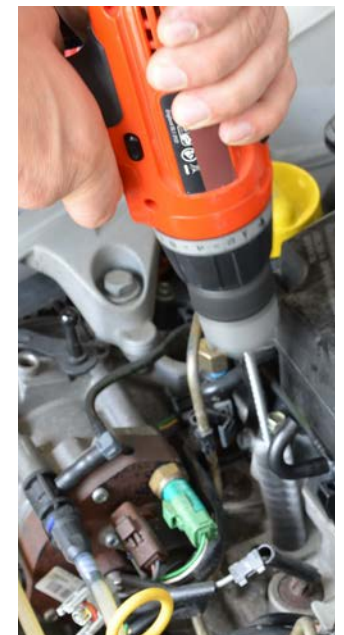

HU41055



UNIVERSAL INJECTOR EXTRACTOR



- Single universal kit that enables all types of moderately frozen or caked injectors to be removed without removing the electrical part, even on the latest vehicles.
- For Denso, Siemens Bosch and Delphi common rail or piezo injectors from 1999 to 2017
- Avoids having to remove the electrical part of the injector and thus avoid significant additional costs due to an extremely strong threaded shaft of the same size as the diesel oil inlet coupling to which the extractor is attached
- The kit also includes two couplings (M12 and M14) in the event that the original coupling cannot be removed
- Two ways of extracting the injector:
 - by rotating (handle)
 - by rotating AND axial extraction (mass to inertia) in the most difficult cases



FOR DENSO, BOSCH, DELPHI, SIEMENS

COMMON RAIL & PIEZO INJECTORS

COMPATIBLE CARS 1999 -> 2017...

UNIVERSAL

PATENTED



NO REMOVAL OF THE ELECTRICAL PART

2 WAYS TO EXTRACT

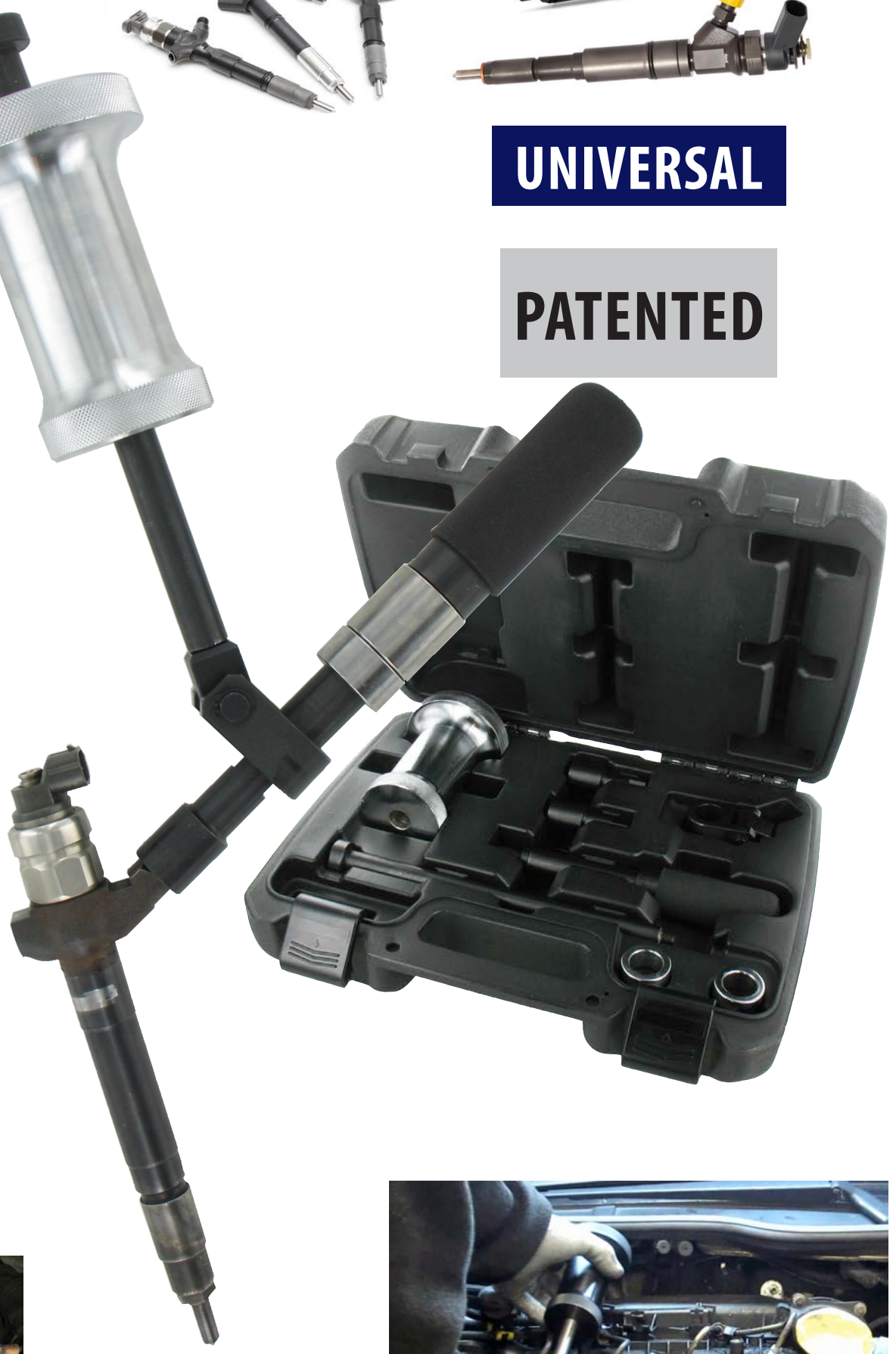
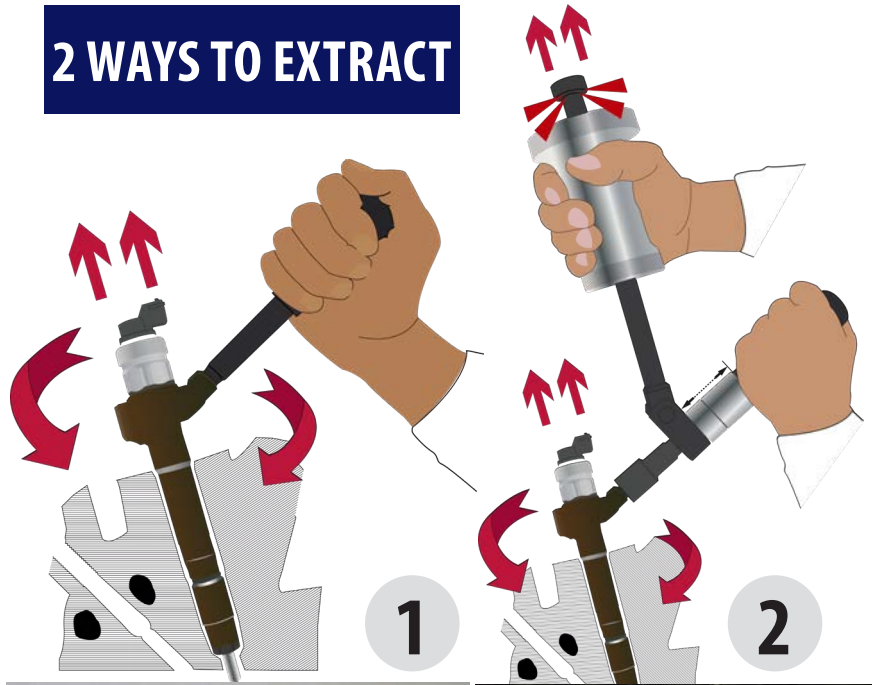

RUSTED

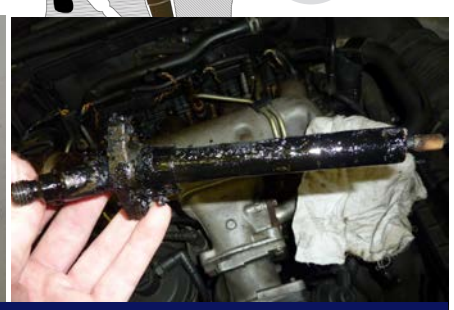

CARBONIZED



EASILY EXTRACT ALL STUCK INJECTORS

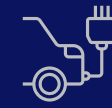

HU41051

UNIVERSAL DIESEL GLOW PLUG PULLER M8, M10X100, M10X125



PATENT PENDING

- Minimal space needed for use : Ideal when glow plug compartment is not easily reachable
- Enables glow plugs broken in the top of the cylinder head to be easily removed without any damage
- Usable in narrow engine bay and engine with glow plugs on the firewall's side
- High quality material for professional use!
- Easy to use:
 - The kit includes 1 electrode puller and 1 electrode reinforced drill with 2 guides
 - It includes 2 special centered mills with one mill support that prevent any damage to the head
 - A tap and a slide-hammer extractor to pull out the broken glow plug
 - 3 refreshing taps : M8 , M10x100 & M10x125 with Hex Drive to be used with any ratchet and self centering feature
- Unique design of Electrode puller to tear out the longest part of the electrode as possible

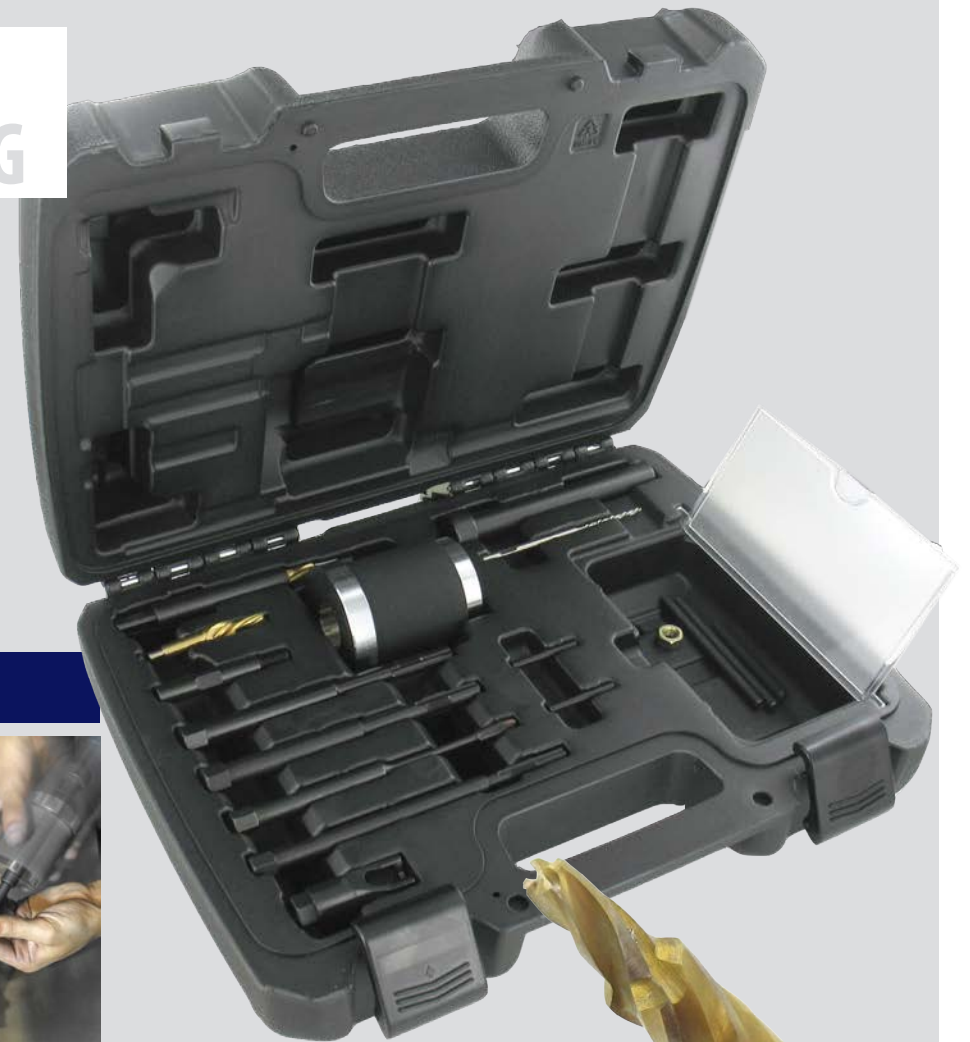

SPECIAL CENTERED MILLS

MINIMAL SPACE NEEDED FOR USE

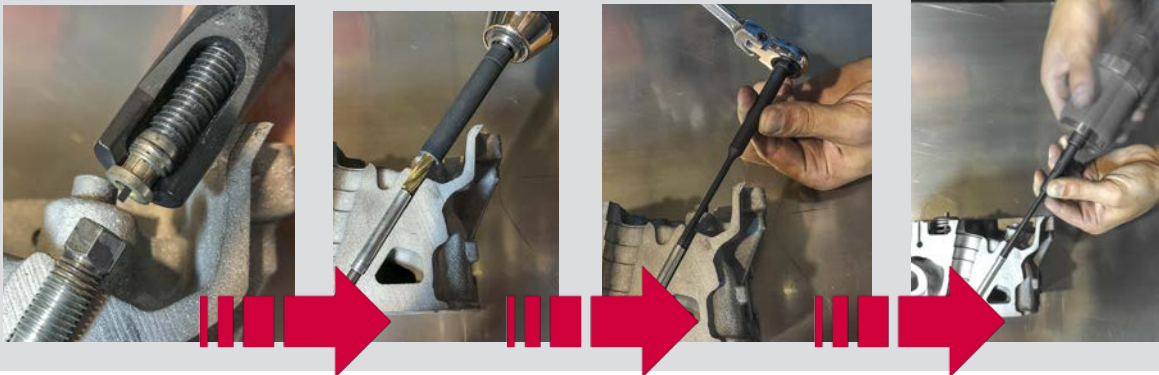

HU41050

BROKEN GLOW PLUG TIPS KIT M8, M9 & M10



PATENT PENDING

- Easy to use in hard to reach places
- Enables broken glow plug tips stuck in the cylinder head to be easily removed
- The kit comprises 4 easily identifiable guides
- The tap, drill bit and extractor holders are fitted to the body of the original plug and slide in instead for perfect centering.
- Self-centering industrial taps
- The size of the drill bits and the shoulder of their holder prevents any risk of drilling or tapping too far into the cylinder head without prior measurement
- In the event of the tips being flared in the cylinder head, the kit has an ejector that enables the tip to be pushed back into the cylinder before retrieving it with the appropriate magnet included in the kit.
- Easy 4 steps operation

REMOVES BROKEN TIPS



- 4 = M10 x 125
- 3 = M10 x 100
- 2 = M9 x 100
- 1 = M8 x 100

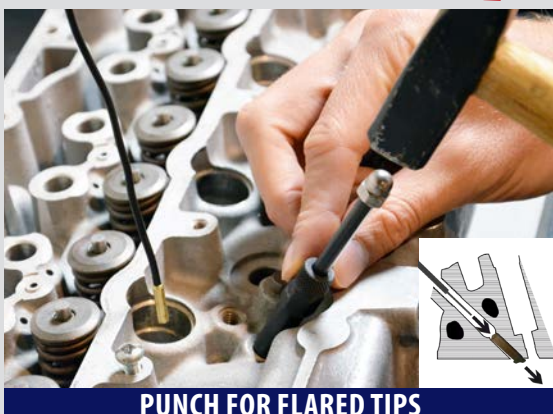

PUNCH FOR FLARED TIPS



SELF-CENTERING TAP

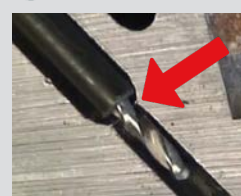

STOP BLOCK -> NO MEASURING NEEDED

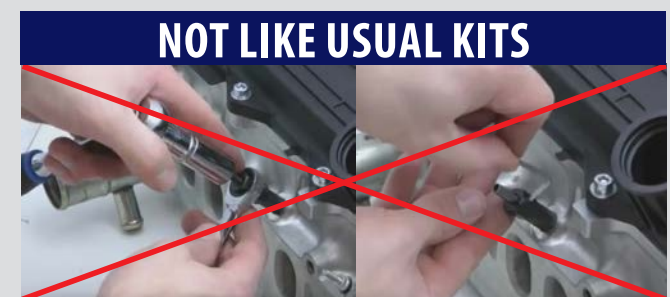

NOT LIKE USUAL KITS

IDEAL TO USE IN HARD TO REACH PLACES

HU41058



GLOW PLUG THREAD REPAIR KIT M8, M9, M10X100, M10X125

- This kit is designed to repair the engine Glow plug threads M8x100, M10x100 & M10x125 quickly, professionally and permanently. It fits perfectly modern vehicles with very little space and access to glow plugs.
- Each tool (reamers & Taps) is self-guided!
- No need for glue or thread seal
- Ream ! Tap ! And replace !

The kit includes:

- 2 Cylinder head reamers: 9mm et 11mm
- 4 Special taps 4 mounting tools
- 4 spare Thread repair inserts of each size M8 x 100 (short & long) ; M9 x 100; M10 x 100; M10 x 125

Spare Thread inserts available separately (see below)

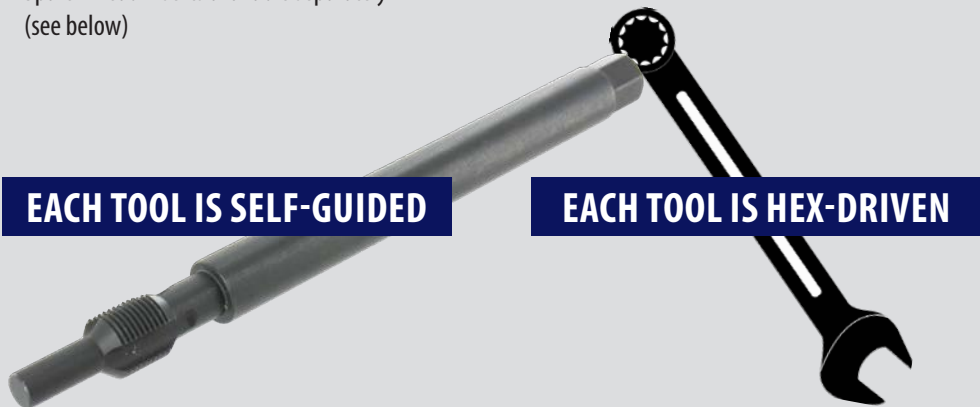

EACH TOOL IS SELF-GUIDED

EACH TOOL IS HEX-DRIVEN

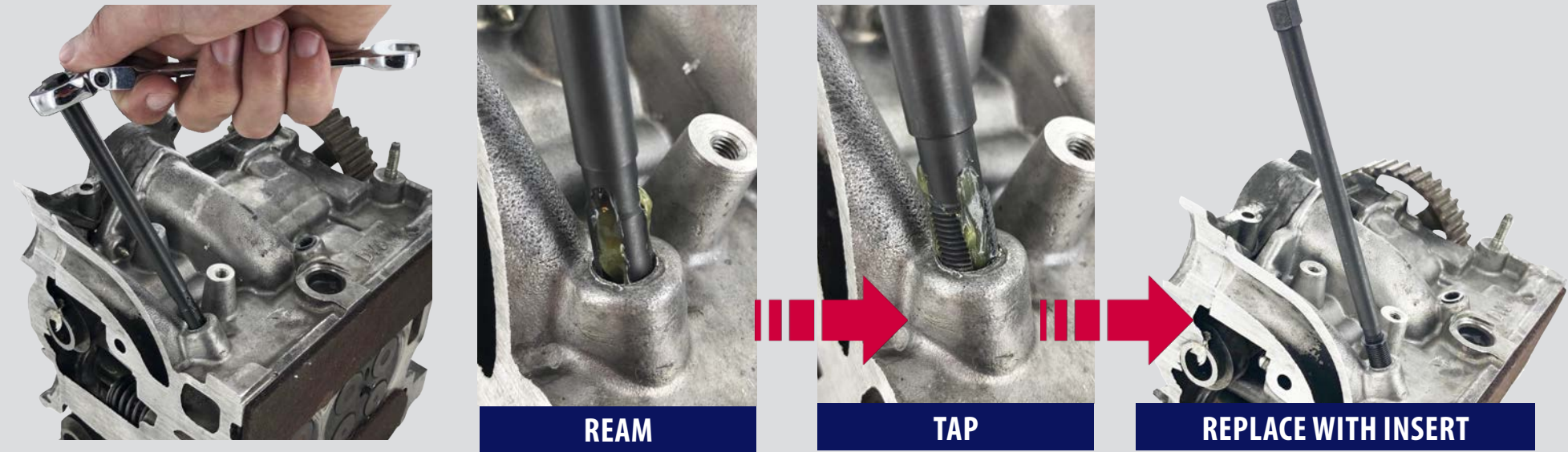

REAM

TAP

REPLACE WITH INSERT

HU41058-17/18/19/20/21



SPARE THREAD REPAIR SETS

- Set of High Quality spare glow plug thread insert. No need for glue or thread seal
- Black oxide finish
- HU41058-21: M8 x 100 Short : 10pcs
- HU41058-20: M8 x 100 Long : 10pcs
- HU41058-17: M9 x 100: 10pcs
- HU41058-19: M10 x 100: 10pcs
- HU41058-18: M10 x 125: 10pcs

IN 10 PCS SETS



HU41058-21

HU41058-20

HU41058-17

HU41058-19

HU41058-18

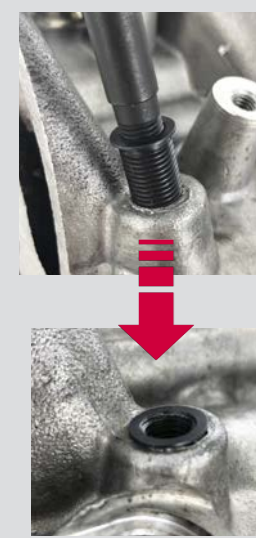

HU46005

CLEAN FUEL EXTRACTOR

- To retrieve fuel following a filling error (gasoline instead of diesel, etc.), remove a submerged fuel pump, change or check the fuel gauge, rinse the fuel tank, during body work, etc.
- Operates off workshop compressed air (no risk of sparks)
- Mobile 45-litre tank (on wheels)
- Cleanly draws up or pushes out fuel
- Anti-static ground cable, overflow line and 5 fuel probes (6, 8, 9.5, 12mm and 16 mm)
- Emptying via injection ramps, the tank filler neck, or fuel lines
- Made of stainless steel



ATEX **94/9/CE**



HU46020

ADBLUE® FILLING STATION WITH DIGITAL METER



- This new station, easily transportable thanks to two large wheels, allows the filling of the AdBlue® safely in any vehicle's tanks.
- The reservoir has a capacity of 45liters.
- The station is fully pneumatic. The filling of the station is done thanks to the venturi and the filling of the vehicle's tank is done on pressure. No need of 230V power.
- The innovative system avoids the risk of contamination, waste, evaporation, and leaks of AdBlue®.
- Closed system: The AdBlue® liquid will never be in contact with any exterior agents

FEATURES

- Air power 4 / 9 Bar
- Filling flow of the vehicle reservoir 18l/min
- Filling of the tank of the station 6l/min
- 45l Stainless steel reservoir with level indicator
- Suction tube
- Security valve
- Autonomy: Station can be disconnected and still be used to fill the vehicles. (Pressure manometer on the station)
- No spill of AdBlue® after filling thanks to the nozzle valve: avoid to damage paint and inside carpets.
- Integrated flow meter to estimate the AdBlue® liters added

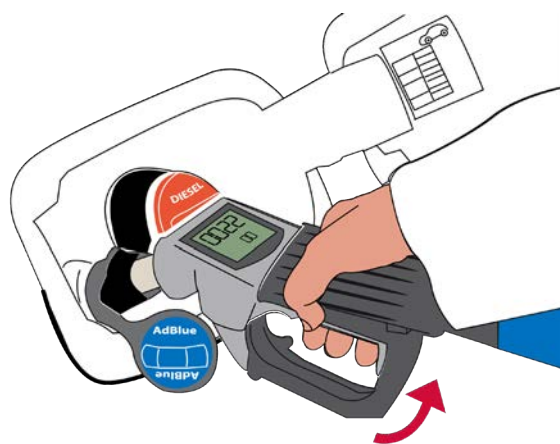

FOR QUICK ADBLUE FILLING

PNEUMATIC STATION

45L RESERVOIR



HU42025



Lugdriller LOCKING LUG NUT REMOVAL KIT
HUBITOLS DESIGN



HUNDREDS OF LOCKING LUG NUTS ON THE MARKET!



LOST KEY? DAMAGED KEY? DAMAGED LUG?



IS THIS YOUR SOLUTION???



ONLY ONE SOLUTION:

Lugdriller
HUBITOLS DESIGN

- The Lugdriller™ is the Ultimate tool to remove the most difficult locking lug nuts in the quickest and safest way. Over the years the locking lug nuts have been dramatically improved. Their design is more and more complex and the material itself harder and harder. Problems with damaged lug nuts or lost keys are well-known in the tire repair shops business.
- Removes the most difficult locking lug nuts
 - Professional kit : made of solid material that can work on the hardest lugs
 - Very easy and quick to use : +/- 8 minutes per wheel only!
- UNIVERSAL :
- Works on all types of sockets from any brand
 - Also works on all modern cars with oddly shaped lugs
 - Also works on damaged lugs



THE ONLY TOOL THAT TRULY WORKS FOR ALL OF THEM

PATENT PENDING



HU42066

THE SPECIAL WHEELS SOCKET SET!

- Works on Kia/Hyundai, Mercedes, Maybach, Opel and Smart
- Square drive : 1/2"
- Ideal to complete Lugdriller kit
- One set for most of special wheel sockets



HU43012

SILENT TYRE VALVE DEFLATOR



Deflating operation by unscrewing the tire valves (Car, Truck, bus) exposes technicians to noises that can lead to deafness

The Silent Tire Deflator patented by INRS allow to reduce noises emissions during tire deflation .

Features:

- The Silent tire Deflator is equipped with a filter cartridge that reduce the noise from 115db to 85db!
- His retractable screwdriver allow the technician to dismount easily and with one hand only the tire valve
- Furthermore the use of this avoid the ejection of the valve during its dismounting



STE99719

LOW PROFILE TIRE REMOVAL TOOL

D30°angled handle design and extra long length provide increased leverage

- Super-grip knurled handle for increased grip
- Durable high strength carbon steel construction
- Trapezoidal design to avoid bending

BENEFITS:

- Ideal for low profile and run-flat tires
- Reduces strain on users hand and wrist
- Provides technician better control of the tool on stiff sidewalls
- Helps protect against damaging expensive wheels



NEW

HU23135

WIFI SWITCH PROBE ENDSCOPE



- Fast Wi-Fi connexion to use with smartphones
- Professional device with excellent price for value
- Easy to share pictures and videos through all smartphones applications (Messenger, Whatsapp, Email...)
- Space saving : allows maximum freedom of movement

- 4,9mm dual camera probe
- Dual Led lights
- 105cm semi hard probe
- Perfect resolution for smartphone
- Variety of probe accessories
- Wi-Fi box with magnetic body for ease of use
- Usable for 2 hours with one battery charge
- USB to Micro USB charging cable
- Magnet for smartphone (stick it or slip it between phone and cover)

Smartphone app functions

- Take pictures
- Make videos
- Adjust light
- Passes from front view to side view



FREE APP AVAILABLE

*Smartphone NOT included in the kit

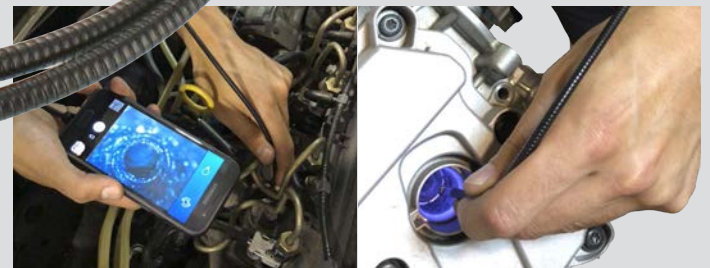
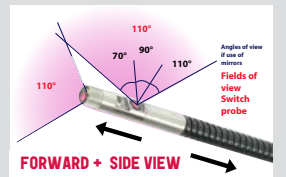

PROVIDES MAXIMUM FREEDOM OF MOVEMENTS

MAGNETIC BODY FOR EASE OF USE

HU23079

4.5MM ANALOG 2 WAYS ARTICULATION PROBE WITH EXCLUSIVE



4.5MM IDEAL FOR COMMON RAIL ENGINE

- Higher resolution : 640x480 with 4 LED
- Diameter is 4.5mm with 1 meter
- Articulation angle is over 170 degree : No need for mirror adapter for side view
- Light Boost in dark area
- 90° image rotations
- The 13mm shorter distal tip of camera head allows to articulate in smaller space
- Automotive applications : Ideal for Common Rail engines, Air condition system, Exhaust system, Diesel injection ports, Glow plug ports, Power window ports, Lock of trunk

SHORT HEAD



Ø 4.5MM

180°

For Exclusive command box features see next page



STE78684

BLUETOOTH CHASSIS EAR



The Steelman®PRO Bluetooth® CHASSISEAR® - NVH is a noise, vibration, and harshness detection tool that uses Bluetooth® wireless technology along with a Windows® or Android™ device to help identify and diagnose unidentified noises. The intuitively designed software provides easy pinpointing of noises from multiple locations. Sound files can be saved and e-mailed to be reviewed by the customer or for further analysis by other technicians.

- Record function allows for capture of sound data
- Multi-Band Equalizer to isolate sound
- Email capability
- Four graph types for visual diagnostics
- Docking Station charges Bluetooth® Modules

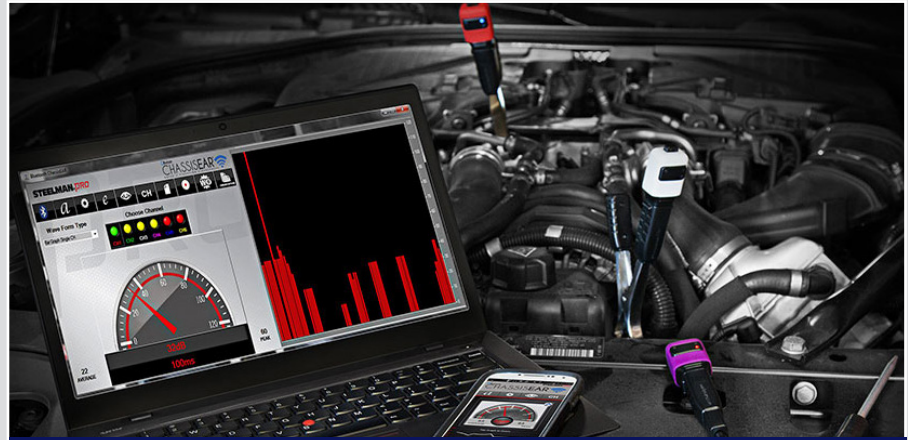

WINDOWS & ANDROID



4 GRAPH TYPES



4 COLOR-CODED SENSORS



RECORD AND SEND BY E-MAIL



HU11010

NEW

BRAKE FLUID BOILING POINT TESTER



- Power supply by the vehicle battery; (12V)
- Precision testing of the boiling temperature of the brake fluid (wet boiling point) in °C and °F
- DOT3/4/5 compatible
- No adjustment to be made by the user, no selection of fluid.
- A single control button -> very simple in the garage
- Clear indication of the recommended boiling T° for DOT 3/4/5 on the screen.
- Auto-protected system: If immersion in the fluid is not deep enough it is safe.
- Intelligent system: If the vehicle battery is too flat or overcharged, it will warn the user. If an internal element is faulty, it will also warn the user.
- Removable electrical heating element / available as a spare part.
- Can be washed with clean water -> allows the boiling point of water (100°C) to be tested to check the accuracy of the equipment.
- EC approved
- One test = max. 30 seconds
- 12V = No risk associated with 220V



ALLOWS THE CONDITION OF THE BRAKE FLUID TO BE CHECKED (THEREFORE MOISTURE PRESENT) BY BOILING

HU42067

NEW

WHEEL HUB GRINDER SET

Quick and easy removal of rust and dirt from contact surfaces of wheel hubs, brake discs and Drums before re-assembly

- This operation helps to prevent the bad balancing and aftersales problems
- To be used with pneumatic, cordless and corded drilling machines
- Each pad is securely screwed on the holder (no Velcro)
- For wheel hubs with or without stud bolts (diameter of grinding zone 40mm) Wear-resistant: approx. 50 vehicles per wheel
- Usable even in humid conditions
- Competitive price



AB70854

BRAKE BLEEDER KIT - 800ML



- Uses compressed air to generate deep vacuum to bleed old fluid and air from hydraulic brake system
- Auto refill unit maintains correct fluid level during bleeding process
- Reduces repair times increasing productivity and profit
- New design with unique patented built in safety valves to prevent accidental fluid spray and spillage

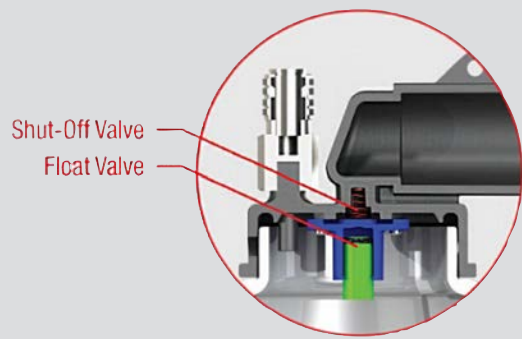

AB70915

4 IN 1 BRAKE PAD SPREADER

ELECTRIC PARK BRAKE



PERFECT FOR ELECTRICAL HAND BRAKE



- A lot of modern cars are mounted with electrical hand brakes. The AB70915 is the ideal tool to push back the pistons of those type of brakes.
- Fast and easy to use
- Powerful : generates over 215kg of force
- Universal adapter : fit single, twin or quad piston
- Prevents damage to pistons, seals or calipers (no pliers, no screwdrivers)
- All pistons are retracted at the same time - no piston getting out



SINGLE



TWIN



QUAD

HU11006

AUTOMATIC BRAKE BLEEDER 12V - 6BAR



- Easy, simple and reliable
- Portable and self-powered
- Compatible with ABS / ESP systems
- 12v powering with reverse polarity warning
- Stainless steel body
- Pump with automatic power off valve
- Regulator from 0 to 6Bar
- 5l reservoir with visible level and min level indication
- Auto power OFF when min level
- Large reservoir opening for easy cleaning
- 12V power cable with jack (L: 4m)
- Power cable for brake fluid with quick coupling system (L: 4m)
- Delivered with fluid refill reservoir with chain and screw-on adaptor compatible with 90% of vehicle fleet



4 WHEELS

6 BAR



HU11004

MASTER CYLINDER ADAPTOR KIT

- Suitable for use with most pressure brake bleeders
- Includes European cap adaptor, multi vehicle caps, BMW/Audi, Nissan, Toyota, Mazda & Honda
- This new kit contains master cylinder adaptors and manufacturer specific caps
- Adaptors fit 99% of current master cylinder reservoirs
- Supplied in a custom molded case
- A syringe is included to empty or top off the master cylinder



AB71197

CVT - DSG - G TRONIC - ATF

NEW

QUICKFLOW DRILL PUMP TRANSMISSION KIT



- ! The QuickFlow pump is a high efficiency gear type pump
- ! It is fitted with a folding engagement bracket to allow the pump to be driven by a 3/8" air ratchet
- ! Using the included universal adaptor allows the pump to be driven by most all cordless drills
- ! Adaptors used with QuickFlow Drill Pump to efficiently refill sealed Automatic Transmissions.
- ! Included Pressure Hose with quick couple fittings for quick adaptor interchange
- ! Adaptors manufacture from high strength fibre reinforced polymer with extreme chemical resistance



AD BLUE

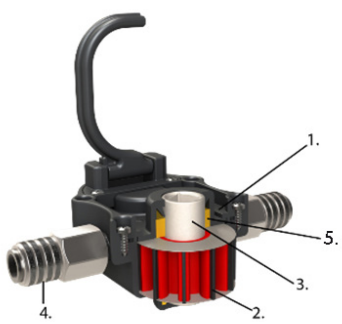

ENGINE OIL

AUTOMATIC TRANSMISSION FLUID

BRAKE FLUID

POWER STEERING

COOLANT



ENGINE OIL PUMP OUTS



GEAR BOX OIL CHANGES



AB70809

UNIVERSAL COOLING SYSTEM PRESSURE TESTER AND KIT WITH CAPS TESTER



BLADER INFLATES TO CREATE SEAL

- ! **Check the system**
AB70802 has an inflatable bladder sealing system that attaches to all passenger and light commercial vehicles (universal use, no need of any adaptors)
- ! **Check the caps**
AB70809 features 6 unique double ended adaptors that suit the most common caps
- ! **Locate leaks from:**
 - head gaskets
 - radiator and heater cores
 - welch plugs and housings
 - water pumps and hoses

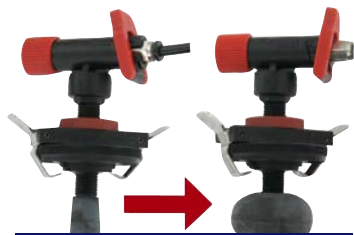

DIAMETER UP TO 60MM



ALSO TESTS CAPS



HU34036

1200A

4-CELLS TECHNOLOGY

NEW

1200A - BOOSTER 4-CELLS BATTERY TECHNOLOGY



- 4-cells battery technology enables to start high compression engines such as big 12v diesel engines
- Double overheating protection to avoid any damage : heavy duty Smart Jump cables & battery thermistor
- Smart jump cables also protected against reverse polarity, short circuit and anti-reverse current
- 4 secondary outputs for quick charging laptops, phones, in-car electronics and even car batteries
- LED flashlight with 3 modes: Lighting – Flashing - SOS
- Type-C input (5V3A 15W) for quick booster charge
- Heavy-duty body for garage use
- New style storage pocket for easier in&out handling
- Kit includes jump cables, charger, Micro USB / Micro USB C Type cable



Dimension	227mm L x 100mm H x 32mm W
Weight	650g
Starting Current	500A
Peak Current	1200A
Battery Lithium Iron Phosphate	16000mAh
Lifetime	≥1000 battery cycles



HU34035

1200A

35000mAh

12V + 24V

MULTIFUNCTION LITHIUM JUMP STARTER 1200A



- Lithium Iron Phosphate (LFE)
- Jump start 12V and 24V vehicles
- Running/Charging USB Devices
- For power supply to 12V vehicle products or 12V electronics such as inflator, cooler, OBDII memory saver, etc.
- LED flash light
- Kit includes multi-pin USB cable and plug charger



UP TO 2000 CYCLES

ADVANTAGES



- Weight : 3 times lighter than a lead booster
- More punchy at the start of the ignition
- More charging/discharging cycles
- Discharge to 5V and charge back to 100%
- Storage life : 120 days without maintenance

Dimension	292x233x79mm
Weight	2680g
Starting Current	12V 600A ; 24V 300A
Peak Current	12V 1200A ; 24V 600A
Battery Lithium Iron Phosphate	35000mAh
12VDC Power Output	10A
USB Output	5VDC, 2A x 1 and 1A x 1
LED Flash Light	3W / 250 Lumens
Fully Charging Time	About 7 hours
Lifetime	>2000 cycles

HU34027

BATTERY CHARGER/MAINTAINER/ POWER SUPPLY 1.5/10AMP

Start (A) Stop

- All in one, 12V charging mode:
 - SLI, AGM SPIRAL, AGM FLATPLATE, GEL, VRLA, CAL/CAL and START-STOP LEAD ACID battery & LFP batteries
 - Start & Stop EFB/AGM
 - Lead-acid batteries and Lithium batteries
- Power supply mode (10AMP Flash Mode & Show Rooms)
- Save deeply discharged battery (Repair Mode as low as 2V)
- Protection : over-charging, Spark free, Reverse polarity, Temperature compensation, IP65

9-STAGE CHARGING ALGORITHM

FULL AUTOMATIC

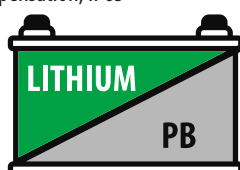

HU31025

THE ULTIMATE AUTOMOTIVE TESTER

NEW

SCOPE +

YouTube™

**EASY TO USE -
AUTORANGE**

- ! Solely designed for automotive electrical circuit's trouble shooting!
- ! Easy and simple to use; no extensive electrical knowledge needed.
- ! Fully protected. Will not cause damage even accidentally using OHM measurement to measure Volts.
- ! Measures:
 - Amps draw (Mini, ATC or Maxi) without removing the fuses from the Fuse Box
 - Voltage (max. 50VDC)
 - Cranking Volts with auto HOLD function
 - Resistance [Ohms] (from 0.0 Ω up to 1.0 MΩ)
 - Frequency with peak to peak volts (up to 20 KHz)
 - and Duty Cycle (%)
- ! In addition, it performs:
 - Continuity test
 - Diode/ LED test

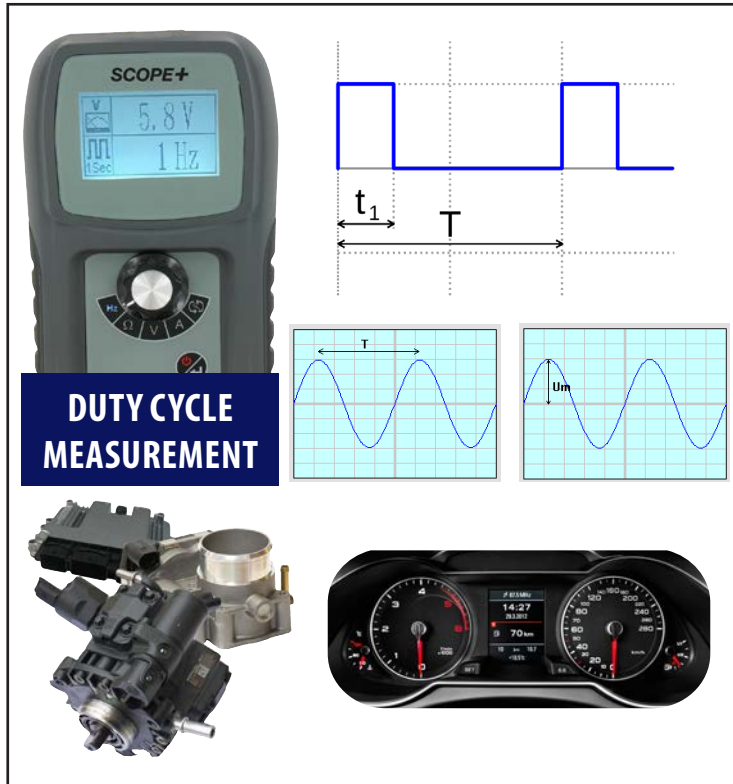

HU31022

DIAGNOSTIC TEST LEAD SET

YouTube™

- ! Complete lead kit for Automotive diagnostics
- ! All leads are arranged properly in pairs "Male & Female" and by terminal sizes
- ! Includes ATC adapter
- ! Includes Piercing Extra Sharp Probes .
- ! New variable resistor of with 10KΩ (instead of 5KΩ) dial indicator
- ! Airbags simulator
- ! Replaceable resistors! 3 of 2 ohms - 2,2 ohms – 2,7ohms
- ! LED Stroboscope
- ! Also includes general purpose components ; Alligator clips, Banana plug to be used with multimeters, 3 ways extension plugs and detachable test probes
- ! Ultra thin lead for multipins connector



HU31035



SENSOR SIMULATOR

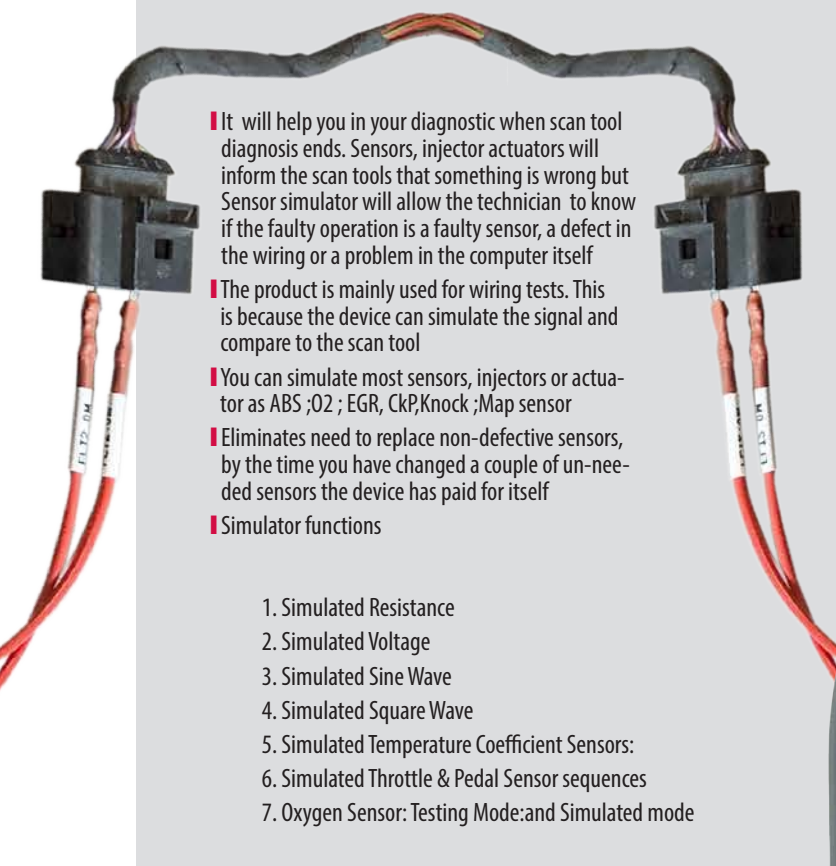

THE IDEAL TOOL TO SIMULATE AND ACTUATE THE OUTPUT SIGNAL FROM AUTOMOTIVE SENSORS: FREQUENCY, VOLTAGE AND TEST SEQUENCES

- It will help you in your diagnostic when scan tool diagnosis ends. Sensors, injector actuators will inform the scan tools that something is wrong but Sensor simulator will allow the technician to know if the faulty operation is a faulty sensor, a defect in the wiring or a problem in the computer itself
- The product is mainly used for wiring tests. This is because the device can simulate the signal and compare to the scan tool
- You can simulate most sensors, injectors or actuator as ABS ;O2 ; EGR, CkP,Knock ;Map sensor
- Eliminates need to replace non-defective sensors, by the time you have changed a couple of un-needed sensors the device has paid for itself
- Simulator functions

1. Simulated Resistance
2. Simulated Voltage
3. Simulated Sine Wave
4. Simulated Square Wave
5. Simulated Temperature Coefficient Sensors:
6. Simulated Throttle & Pedal Sensor sequences
7. Oxygen Sensor: Testing Mode:and Simulated mode



HU31030



CORDLESS SOLDERING IRON



- Warm-up time: 10-15 seconds
- Runtime: 35 min real
- Can also be used connected to the mains (charging)
- Lithium Battery = 500-700 charge cycles
- No 220V => no risk associated with the current.
- 30W: high power for a small device.
- Unlike gas soldering irons, this does not involve any flame. Fire is not permitted in garages for obvious safety reasons.
- No adjustment as with gas irons.
- No ordering and shipping of gas (speaking logistically, shipping gas is problematic. e.g. by plane)
- No cable. Very mobile with a high runtime.
- Precision tip for fine solders (connectors, etc.)
- Universal tip for soldering cables (e.g. cabling a trailer hitch)
- Tip for heat-shrink sheaths: Does not come into contact with the sheath so it doesn't melt it.
- Its heating speed makes work easier: No need to heat the iron 10-15 minutes before starting work. Here it heats up in 10-15 SECONDS.
- Case remains cold throughout the operation.

Accessories Contained in the Kit

- 3 x ¼-turn tips: Universal tip, fine-pointed tip and tip for heat-shrink sheath
- Micro-USB charging cable
- Iron rest
- Ø 1.0mm wire
- Cleaning sponge
- Thermal protective cap and circuit breaker.

Equipment

- Soldering iron with a power of 30 W
- Ergonomic and solid case, sliding "start – stop" button + push button to activate heating.
- LED light
- Supply by 2200 mAh 3.7V rechargeable LITHIUM-ION BATTERY.

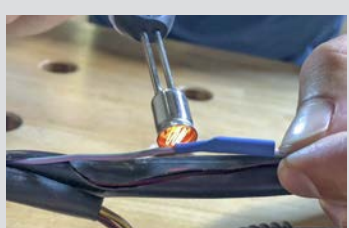

TIP FOR HEAT-SHRINK SHEATHS



UNIVERSAL TIP



PRECISION TIP FOR FINE WELDS



REMOVABLE TIPS

HU34039

NEW

USB BATTERY & ELECTRICAL SYSTEM ANALYSER



- TESTS ALL TYPES OF START&STOP AND STANDARD BATTERIES!
- A USB connection gives the technicians the possibility to download the results on their computer and share them with others and upload future updates on the tester
- Standard size paper rolls
- Possibility of inserting a CR2032 battery for date & time memory
- Handy design with large illuminated digital screen
- 3 functions : Battery test, System Test (Alternator) and « in vehicle » test (Battery test and System test combination)
- Tests 12V batteries and 12V-24V charging systems (FLOODED, AGM FLAT PLATE, AGM SPIRAL, VRLA/GEL, EFB)
- 6 Languages (EN, FR, ES, DE, IT, PT)
- Rating&range : CCA/SAE: 40~2000

EN: 40~1885
DIN: 25~1120
IEC: 30~1320
JIS: By Battery Type No.
CA/MCA: 50~2400

Start (A) Stop
AGM & EFB



HU34034

NEW

BATTERY & ELECTRICAL SYSTEM ANALYSER

- TESTS ALL TYPES OF START&STOP BATTERIES AND STANDARD BATTERIES!
- Handy design with large illuminated digital screen
- 3 functions : Battery test, System Test (Alternator) and « in vehicle » test (Battery test and System test combination)
- Tests 12V batteries and 12V-24V charging systems (FLOODED, AGM FLAT PLATE, AGM SPIRAL, VRLA/GEL, EFB)
- 6 Languages (EN, FR, ES, DE, IT, PT)

Rating&range : CCA/SAE: 40~2000
EN: 40~1885
DIN: 25~1120
IEC: 30~1320
JIS: By Battery Type No.
CA/MCA: 50~2400

Start (A) Stop
AGM & EFB



HU34012

START & STOP BATTERY & ELECTRICAL SYSTEM ANALYSER WITH PRINTER



YouTube™

- Specially designed for Start & Stop systems
- Exclusive design by Hubitools
- Tests 6V-12V batteries and 12V-24V volt charging & starting systems
- Integrated printer
- Digital screen
- Operating range: 40 ~ 2000 CCA
- Tests EFB, VRLA / GEL , AGM Flat Plate, AGM Spiral and Regular Liquid batteries in 2 seconds

Rating system: SAE (CCA)/ DIN / EN / IEC and JIS
6 languages available

Start (A) Stop
AGM & EFB

